



**LINGENFELTER**<sup>™</sup>  
P E R F O R M A N C E E N G I N E E R I N G

**Lingenfelter STOV-001**  
**Speed to Voltage Converter**  
**&**  
**Speed Based Relay Control Module**  
*(MPH activated switch)*



**LPE-STOV-001**

1557 Winchester Road  
Decatur, Indiana 46733  
260 724 2552 phone  
260 724 8761 fax  
[www.lingenfelter.com](http://www.lingenfelter.com)



## Parts List

#	Part number	Description
1	STOV-001	LPE Speed to Voltage Converter
1		hook & loop tape
2	AV16037	self-tapping screw
1		LPE decal
1		instructions

## Specifications:

- The Lingenfelter Performance Engineering STOV-001 Speed To Voltage Converter and MPH Activated Switch incorporates a precision 32-bit timer to realize microsecond precision over a very wide operating MPH range.
- Designed to work with most late model GM vehicles that have a 4000 pulse per mile (PPM) vehicle speed output from the ECM/PCM including:
  - 1997-2008 Corvette (C5 and C6)
  - 1998-2002 LS1 Camaro and Firebird
  - 2004-2006 GTO
  - 2003-2006 SSR
  - 2006-2008 Trailblazer SS and other 5.3 and 6.0L S/T trucks
  - 1999-2008 CK trucks (Tahoe, Yukon, Escalade, Sierra, Silverado)
- Fully encapsulated (potted) construction for increased durability.
- Rated for operation at up to 185 degrees F (85 degrees C).
- Outputs rated for up to 2.0 amps. For higher current levels, the switch should control a relay.
- Both the normally on and the normally off outputs can be used simultaneously.
- Offers the following output capabilities:
  - GM ECM/PCM vehicle speed output frequency to voltage conversion (available in all modes)
  - MPH activated switch with Normally Open and Normally Closed ground active outputs.
  - Stage/gear shift simulator for boost controllers and other devices that need to see a gear shift position switch output to changes stages, such as:
    - AMS-1000 boost controller from NLR Systems
    - Innovative Turbo Systems MSBC01 Multi-Stage boost controller
- Outputs have a self protect feature and will turn OFF in case of a short or over current condition.
- Operating voltage range: 9.0 to 16.0 volts.
- Input signal type: PPM square wave 12 volt DC.
- Input signal impedance: 15k Ohm.
- Current draw: less than 0.1 amp plus current draw of device being controlled (when active).
- Warranty: 90 days from date of purchase.





## **STOV-001 basic operation description:**

Speed input signal is GM Engine Control Module (ECM) or Powertrain Control Module (PCM) 4000 pulse per mile (ppm) signal from most newer GM vehicles.

Analog voltage output is 0-5 volt analog output proportional to speed. Speed range is 0 – 250 mph (0 volts = 0 mph, 5 volts = 250 mph). Analog output will increase at a rate of .02 volt per mph (linear relationship between speed and voltage). The analog voltage output function operates the same in all modes.

The analog voltage speed output can be used to feed vehicle speed to auxiliary data acquisition systems or to feed vehicle speed to devices that are not able to read the vehicle speed pulse data directly (some boost and nitrous controllers).

Two Ground active outputs.

16 position Function switch to select operating mode.

16 position Range switch to select output configuration.

## **Stage/gear simulator Function output control mode (Function switch setting 0):**

Operation as mph increases - when 1<sup>st</sup> table entry is reached green wire “Activation” output will turn on (provides a ground signal), starting Stage1 boost control. This output will remain ON until mph drops below 1<sup>st</sup> table entry.

As mph increases and becomes greater than or equal to next table entry the gray wire “Next Stage” output will turn ON (provides ground signal) for .1 second then turns back OFF. This provides pulse to increment boost controller to the next stage. This process continues as mph increases until the last table entry is reached and/or a table entry is equal to 0.

As the mph decreases the “Activation” output will remain ON until mph is below 1<sup>st</sup> table entry. Then the “Activation” output turns OFF resetting the boost controller. If mph increases the above sequence is performed again.

## **MPH switch Function control mode (Function switch setting 1, 2 or 3):**

When vehicle speed exceeds the value set in Table B with the Function and Range switches, the Normally Open (NO or OFF) activation wire connects to ground and the Normally Closed (NC or ON) wire will open the ground path (was connected to ground before activation).

When the vehicle speed drops one mph below the value set in Table B with the Function and Range switches the processes reverses itself and the Normally Open (NO or OFF) activation wire will open the ground path and the Normally Closed (NC or ON) wire will connect to ground.

## **Vehicle speed to voltage conversion function (any Function switch setting):**

The 0-5 volt Analog and Switched outputs will work simultaneously and either and/or both may be used at the same time.



## Wiring (also labeled on module):

Wire Color	Label	Notes
White	PPM Signal In	This is the vehicle speed pulse input. This connects to the ECM/PCM output signal
Yellow	Voltage Out	This is the vehicle speed output voltage (analog voltage output). This is a 0-5 volt DC output.
Green	Activation Out / Normally Off	This is one of two output wires. When used in MPH activated switch mode this connects to the ground side of the device you plan to activate.
Gray	Stage Out / Normally On	This is the second output wire. When used in MPH activated switch mode this connects to the ground side of the device you plan to activate.
Black	Ground	Connects to a vehicle ground.
Red	+12	Connects to a switched +12 volt source.

## Red LED:

- Blinks whenever target mph is reached.

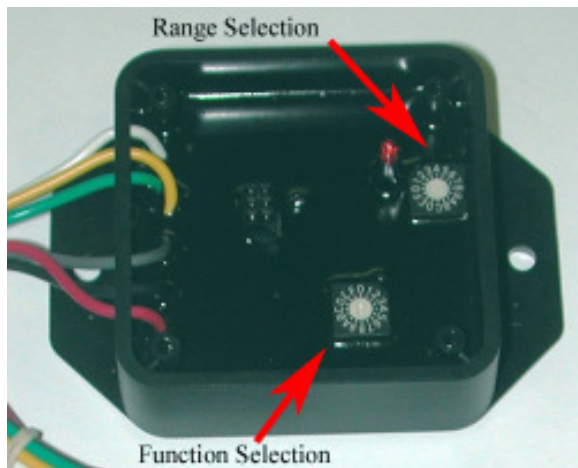

## Installation:

- Remove negative battery terminal.
- Connect black wire of MPH switch to a suitable vehicle ground.
- Connect the red wire to a **switched and fused** +12 volt DC source.
- Connect the white wire to the ECM or PCM speed signal output wire (consult service information or contact LPE for your specific vehicle application).
  - See Table C on page 8 for sample PCM/ECM vehicle speed output pin/wire locations.
- Connect the output/control wires (green and gray) as needed for your application.
  - See page 5 for example wiring schematics for MPH switch function.
  - See page 6 for example wiring schematics for use with the LPE LNC-001R launch controller.
- Reconnect the negative battery terminal.



Table A							
Speed (mph)		gear change					
		1	2	3	4	5	
range switch position	0	0	30	60	110	140	175
	1	1	25	50	95	125	155
	2	2	20	45	90	115	140
	3	3	20	40	80	105	130
	4	4	40	75	120	175	220
	5	5	35	70	115	170	210
	6	6	30	65	105	150	200
	7	7	55	80	110	140	190
	8	8	50	75	100	130	175
	9	9	45	70	95	125	165
	10	A	40	65	90	120	160
	11	B	47	80	123	164	200
	12	C	44	75	116	154	190
	13	D	38	65	100	133	180
	14	E	35	60	92	122	166
	15	F	32	55	85	113	152

Table B				
Switch Position	Speed in mph (mode)			
	Low (1)	Std (2)	High (3)	
range switch position	0	OFF	OFF	OFF
	1	1	10	110
	2	2	20	120
	3	3	30	130
	4	4	40	140
	5	5	50	150
	6	6	60	160
	7	7	70	170
	8	8	80	180
	9	9	90	190
	A	10	100	200
	B	11	110	210
	C	12	120	220
	D	13	130	230
	E	14	140	240
	F	15	150	250

**Settings:**

- Controlled by two (2) sixteen (16) position switches (as labeled on page 3).
  - One switch is for selecting the Function. The following functions (modes) exist at this time:
    - Switch setting 0 enables the gear change simulation function (Table A).
    - Switch setting 1 enables the low speed range (Table B, Low (1)) mph activated switch function, .
    - Switch setting 2 enables the standard speed range (Table B, Std (2)) mph output switch function.
    - Switch setting 3 enables the high speed range (Table B, High (3)) mph output switch function.
  - Second switch is for selecting the Range (within table A or B)

**Notes:**

- **Changes to the rpm switch point settings must be done with the ignition off**
  - The switch positions are only read on start up



## Signal Disable Installation, Function Switch set to Position 1

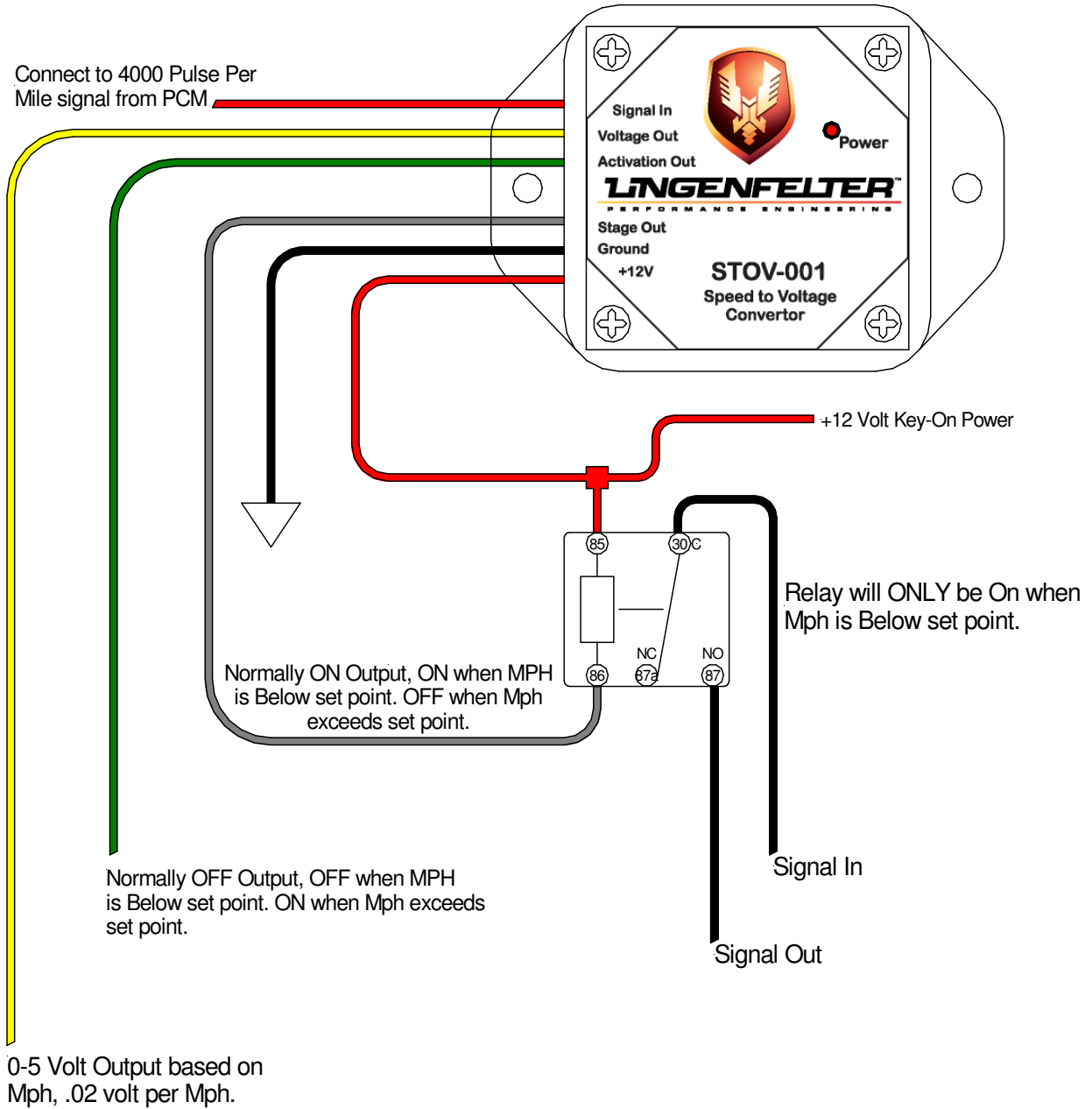



## 1998-2002 F-Body and 1997-2008 Corvette Factory Clutch Switch Diagram with STOV-001.

- 1 - Locate CPP (Clutch Position Switch) and unplug 2-wire connector.
- 2 - Cut wires approx. 3" back from connector.
- 3 - Find +12 volt Key On power source and connect to one wire of CPP connector.
- 4 - Splice two wires onto remaining CPP connector wire and connect one wire to #85 on Relay. The extra wire will be used for LNC-001 Launch Controller activation.
- 5 - Connect terminal #86 on Relay to Ground.
- 6 - Connect wires cut from CPP Switch connector to Terminals #30 and #87 as shown. Wire color may vary for model/year.

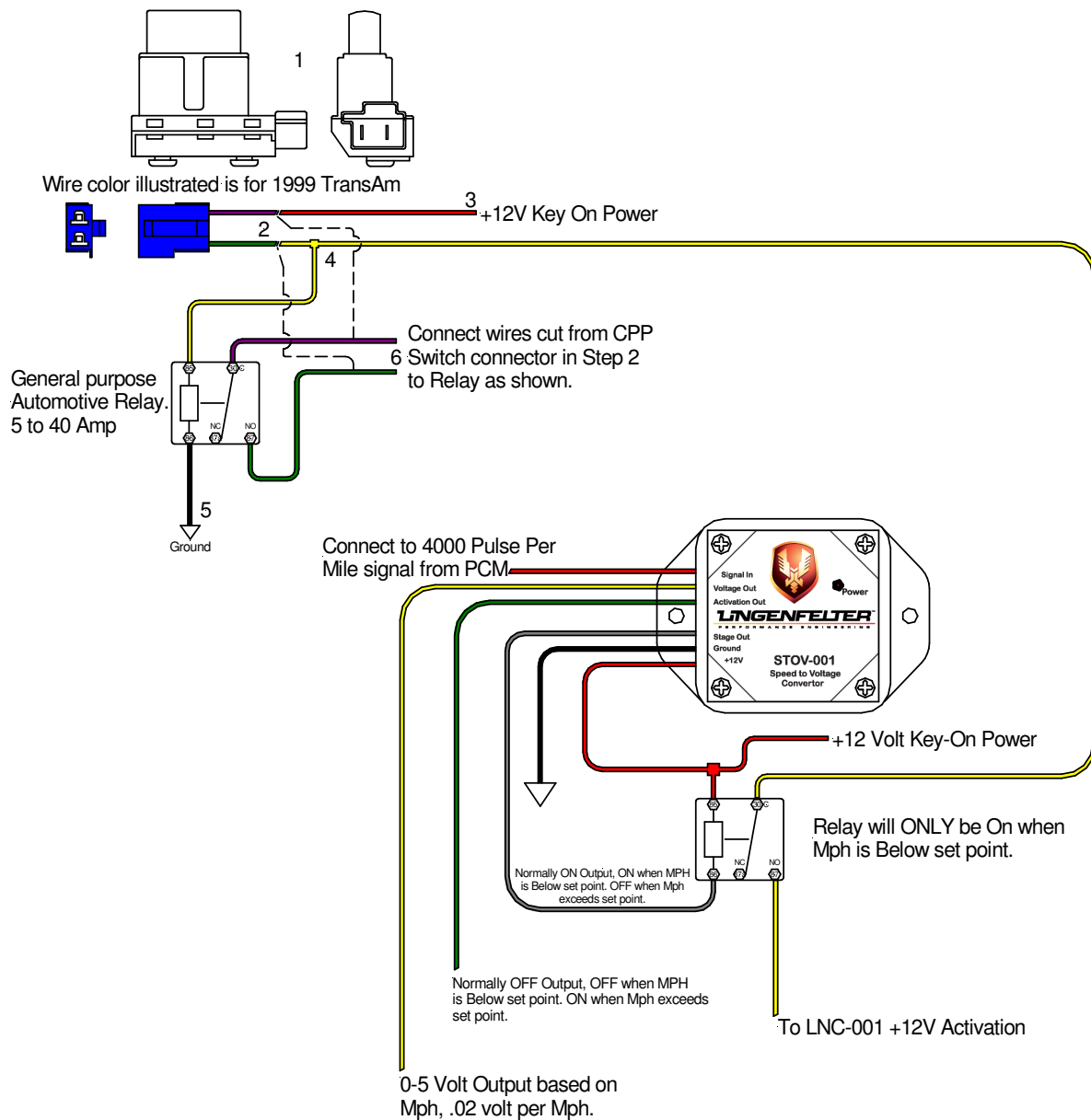



<b>PCM/ECM vehicle speed output information:</b>					
<b>Vehicle</b>	<b>Year</b>	<b>ECM/PCM Connector</b>	<b>Pin</b>	<b>Wire Color</b>	<b>Circuit Number</b>
Camaro and Firebird	1998	C1 (Red)	55	DK GRN/WHT	817
Camaro and Firebird	1996-1997	C2 (Black)	8	DK GRN/WHT	817
Camaro and Firebird	1999-2002	C2 (Red)	50	DK GRN/WHT	817
CK truck	1999-2002	C2 (Red)	50	DK GRN/WHT	817
CK truck	2003-2006	C2 (Green)	50	DK GRN/WHT	817
CK truck	2007-2008	C1/X1 (BLK)	57	YE/BK	1827
Corvette	1996	C2 (Black)	8	DK GRN/WHT	817
Corvette	2004	C2 (Green)	50	DK GRN/WHT	817
Corvette	2005	C1 (Blue)	21	DK GRN/WHT	817
Corvette	1997-1998	C1 (Red)	55	DK GRN/WHT	817
Corvette	1999-2003	C2 (Red)	50	DK GRN/WHT	817
Corvette	2006-2008	C1/X1 (BLK)	57	DK GRN/WHT	817
CTS-V	2004-2005	C2 (Green)	50	BN	818
CTS-V	2006-2007	C1 (Blue)	39	BN	818
GTO	2004	C2 (Green)	50	PU/WH	5197
GTO	2005-2006	C1 (Blue)	21	PU/WH	5197
SSR	2003-2004	C2 (Green)	50	DK GRN/WHT	817
SSR	2005-2006	C1 (Blue)	21	DK GRN/WHT	817
Trailblazer SS	2006	C1 (Blue)	21	DK GRN/WHT	817
Trailblazer SS	2007-2008	C1/X1 (Blue)	39	DK GRN/WHT	817

1557 Winchester Road  
Decatur, Indiana 46733  
260 724 2552 phone  
260 724 8761 fax  
www.lingenfelter.com